

SATEL

Mission-Critical Connectivity

SATEL-TR489
TRANSCEIVER
MODULE

INTEGRATION GUIDE

Version 1.1

IMPORTANT NOTICE

All rights to this manual are owned solely by SATEL Oy (referred to in this user guide as SATEL). All rights reserved. The copying of this manual (without the written permission from the owner) by printing, copying, recording or by any other means, or the full or partial translation of the manual to any other language, including all programming languages, using any electrical, mechanical, magnetic, optical, manual or other methods or devices is forbidden.

SATEL reserves the right to change the technical specifications or functions of its products, or to discontinue the manufacture of any of its products or to discontinue the support of any of its products, without any written announcement and urges its customers to ensure, that the information at their disposal is valid.

SATEL software and programs are delivered "as is". The manufacturer does not grant any kind of warranty including guarantees on suitability and applicability to a certain application. Under no circumstances is the manufacturer or the developer of a program responsible for any possible damages caused by the use of a program. The names of the programs as well as all copyrights relating to the programs are the sole property of SATEL. Any transfer, licensing to a third party, leasing, renting, transportation, copying, editing, translating, modifying into another programming language or reverse engineering for any intent is forbidden without the written consent of SATEL.

SATEL PRODUCTS HAVE NOT BEEN DESIGNED, INTENDED NOR INSPECTED TO BE USED IN ANY LIFE SUPPORT RELATED DEVICE OR SYSTEM RELATED FUNCTION NOR AS A PART OF ANY OTHER CRITICAL SYSTEM AND ARE GRANTED NO FUNCTIONAL WARRANTY IF THEY ARE USED IN ANY OF THE APPLICATIONS MENTIONED.

Salon, FINLAND 2022

RESTRICTIONS ON USE – SATEL-TR489

SATEL-TR489 radio transceiver module has been designed to operate on 403-473 MHz, 856-876 MHz and 902-928 MHz, the exact use of which differs from one region and/or country to another. The user of a radio transceiver module must take care that the said device is not operated without the permission of the local authorities on frequencies other than those specifically reserved and intended for use without a specific permit.

SATEL-TR489 is allowed to be used in the following countries. More detailed information is available at the local frequency management authority.

Countries: AT, AU, BE, BG, CA, CH, CY, CZ, DE, DK, EE, ES, FI, FR, GB, GR, HU, HR, IE, IS, IT, LT, LU, LV, MT, NL, NO, NZ, PL, PT, RO, SE, SI, SK, TR, US

WARNING – RF Exposure! To comply with RF exposure compliance requirements in Europe, USA and Canada maximum antenna gain on 400 MHz band is 14 dBi and a separation distance of at least 1.1 meter must be maintained between the antenna of this device and all persons.

This integration guide applies to the combination of Firmware/Hardware version listed in the table below. See www.satel.com for the newest firmware and Integration Guide version.

Firmware version	Hardware version	Note!
07.53.2.5.1.39	SPL0076c	

This radio transmitter 2422A-SATELTA43 has been approved by Innovation, Science and Economic Development (ISED) Canada to operate with the antenna types listed below with the maximum permissible gain indicated. Antenna types not included in this list, having a gain greater than the maximum gain indicated for that type, are strictly prohibited for use with this device.

Antenna type	Manufacturer	Antenna model	Maximum gain (dBi)
Omnidirectional (whip)	Laird Connectivity	FG9026	6
Directional (yagi)	PulseLarsen Antennas	YA6900W	6

NOTE!

According to the requirements of the FCC, the integrator should make sure that the SATEL-TR489 is compliant to part 15B and Part 90 while integrated in the host device. Output power and spurious emissions should be verified.

PRODUCT CONFORMITY

Under the sole responsibility of manufacturer SATEL Oy declares that SATEL-TR489 radio transceiver module is in compliance with the essential requirements (radio performance, electromagnetic compatibility and electrical safety) and other relevant provisions of Directives 2014/53/EU and 2011/65/EU and Council recommendation 1999/519/EC. Therefore, the equipment is labeled with the following CE-marking. The operating frequency range of the device is not harmonized throughout the market area, and the local spectrum authority should be contacted before the usage of the radio module.



For 902-928 MHz

This device complies with ISSED license-exempt RSS standard(s) and part 15 of the FCC Rules. Operation is subject to the following two conditions: (1) this device may not cause interference, and (2) this device must accept any interference, including interference that may cause undesired operation of the device. Changes or modifications not expressly approved by the party responsible for compliance could void the user's authority to operate the equipment.

Le présent appareil est conforme aux CNR d'ISSED applicables aux appareils radio exempts de licence. L'exploitation est autorisée aux deux conditions suivantes : (1) l'appareil ne doit pas produire de brouillage, et (2) l'appareil doit accepter tout brouillage radioélectrique subi, même si le brouillage est susceptible d'en compromettre le fonctionnement.

WARRANTY AND SAFETY INSTRUCTIONS

Read these safety instructions carefully before using the product:

- Warranty will be void, if the product is used in any way that is in contradiction with the instructions given in this manual.
- The radio transceiver module is only to be operated at frequencies allocated by local authorities, and without exceeding the given maximum allowed output power ratings. SATEL and its distributors are not responsible, if any products manufactured by it are used in unlawful ways.
- The devices mentioned in this manual are to be used only according to the instructions described in this manual. Faultless and safe operation of the devices can be guaranteed only if the transport, storage, operation and handling of the device are appropriate. This also applies to the maintenance of the products.

HOST INTEGRATION

To ensure compliance with all non-transmitter functions the host manufacturer is responsible for ensuring compliance with the module(s) installed and fully operational. For example, if a host was previously authorized as an unintentional radiator under the Declaration of Conformity procedure without a transmitter certified module and a module is added, the host manufacturer is responsible for ensuring that after the module is installed and operational the host continues to be compliant with the Part 15B unintentional radiator requirements. This module is certified for Fixed and Mobile Applications only, for portable applications you will require a new certification.

This device has been modularly approved. Model name, FCC and Industry Canada identifiers of this product must appear on the outside label of the end-user equipment.

Host labelling example:

Model Name: SATEL-TR489
Contains FCC ID: MRBSATEL-TA43
IC: 2422A-SATELTA43

This device complies with part 15 of the FCC rules. Operation is subject to the following two conditions: (1) This device may not cause harmful interference, and (2) this device must accept any interference received, including interference that may cause undesired operation.

TABLE OF CONTENTS

IMPORTANT NOTICE	1
RESTRICTIONS ON USE – SATEL-TR489.....	2
PRODUCT CONFORMITY.....	4
WARRANTY AND SAFETY INSTRUCTIONS	5
HOST INTEGRATION	6
TABLE OF CONTENTS	7
1 INTRODUCTION.....	10
1.1 Terms and abbreviations.....	10
1.2 Description of the product	10
2 TECHNICAL SPECIFICATIONS.....	11
2.1 Absolute maximum ratings.....	11
2.2 DC electrical specifications.....	11
2.3 Standard compliance	12
2.4 Specifications, SATEL-TR489 (on 403-473 MHz).....	12
2.5 Specifications, SATEL-TR489 (on 856 – 876 MHz)	15
2.6 Specifications, SATEL-TR489 (on 902 – 928 MHz)	17
3 TIME PARAMETERS FOR STARTUP AND SHUTDOWN SEQUENCES.....	19
3.1 Startup sequence	19
3.2 Shutdown and ENA sequences	20
4 ELECTRICAL INTERCONNECTION.....	21
4.1 DTE connector.....	21
4.2 Pin order of the DTE connector	22

4.3	Equivalent I/O Schematics	23
4.4	RF interface	24
4.5	VCC_IO pin	25
4.6	Service pin.....	25
4.7	Stat pin	25
4.8	VCC pins	26
4.9	UART pins	26
4.10	GPIO pins	26
5	MECHANICAL CONSIDERATIONS	27
5.1	Fixing device to host.....	27
5.2	Heat transfer.....	27
6	OPERATING MODES	28
6.1	Switching frequency band.....	28
6.2	Safe mode	29
6.3	Power up / power down scenarios.....	29
6.4	Sleep Mode.....	29
6.5	Power Save Mode.....	30
6.6	Restart	31
7	CHANGING PARAMETERS USING SL COMMANDS.....	32
7.1	SL Commands.....	32
7.2	SL Command Mode	33
8	DEFAULT DELIVERY VALUES – SATEL-TR489	34
9	CONSIDERATIONS.....	35
9.1	EMI Interferers	35
9.2	Electrostatic discharge	36
9.3	Using the device in unmanned high reliability applications	36
9.4	Proposals for more reliable radio link.....	37

10 APPENDIX	38
10.1 Sub-band Channel Assignment – SATEL-TR489	38
10.2 Module dimensions.....	39
10.3 SL commands list.....	39
11 VERSION HISTORY	40

1 INTRODUCTION

SATEL Oy is a Finnish electronics and Telecommunications company specializing in the design and manufacture of wireless data communication products. SATEL designs, manufactures and sells radio modems intended for use in applications ranging from data transfer to alarm relay systems. End users of SATEL products include both public organizations and private individuals.

SATEL Oy is the leading European manufacturer of radio modems. SATEL radio modems have been certified in most European countries and also in many non-European countries.

This document is the integration guide for the SATEL-TR489 radio transceiver module. It is intended to describe how to use the module and how to integrate it into a host device.

1.1 Terms and abbreviations

Abbreviation	Description
CTS	Clear To Send, handshaking signal used in asynchronous communication.
DTE	Data Terminal Equipment (typically computer, terminal...)
ESD	Electrostatic discharge
RD	Receive Data
TD	Transmit Data
RTS	Ready To Send, handshaking signal used in asynchronous communication.
RAM	Random Access Memory
LDO	Low dropout regulator
UHF	Ultra High Frequency
RF	Radio Frequency
CPU	Central processing unit

1.2 Description of the product

The SATEL-TR489 is UHF radio transceiver module, which transmits and receives data from the UHF frequency band. The module is designed to be as compact and power efficient as possible. They have been developed to be especially suitable for integration into battery powered and space constrained host applications benefiting from UHF communications.

The module transmits and receives data via the Air interface, modulates and demodulates, encodes and decodes the data and sends the received data payload to the DTE port. The DTE interface is used to provide power and communicate with the module.

2 TECHNICAL SPECIFICATIONS

2.1 Absolute maximum ratings

Absolute maximum ratings for voltages on different pins are listed in the following table. Exceeding these values will cause permanent damage to the module.

Parameter	Min	Max
Voltage at VCC_IN	0 V	+6 V
Voltage at ENA_MOD	0 V	+6 V
Voltage at VCC_IO	0 V	3.75 V
Voltage at digital inputs (except ENA_MOD)	0 V	3.75 V
Voltage at digital outputs	0 V	3.75 V

Note. All voltages are referenced to GND.

2.2 DC electrical specifications

Recommended operating conditions:

Parameter	Condition	Min	Max	Units
VCC_IN		+3.8	+5.5	V
ENA_MOD, Vlow		0	0.2	V
ENA_MOD, Vhigh		1.2	VCC_IN	V
VCC_IO		1.8	3.3	V
Logic input, Vlow	1.8 V < VCC_IO < 3.3V	0	0.3	V
Logic input, Vhigh	1.8 V < VCC_IO < 3.3V	0.9*VCC_IO	VCCIO	V
Logic output, Vlow	1.8 V < VCC_IO < 3.3V	0	0.5	V
Logic output, Vhigh	1.8 V < VCC_IO < 3.3V	0.6*VCC_IO	VCCIO	V
Logic output, max current	All logic output except STAT pin.	-	4	mA
Logic output, max current, STAT pin		-	12	mA

2.3 Standard compliance

SATEL-TR489 complies with the following international standards:

- EN 300 113
- EN 300 220-1, -2
- EN 301 489-1, -3
- EN / IEC 62368-1
- FCC Parts 15.209 and 15.247 of Title 47
- IC RSS-247, ICC RSS-Gen

2.4 Specifications, SATEL-TR489 (on 403-473 MHz)

	RECEIVER	TRANSMITTER	Note!
Frequency Range	403-473 ¹ MHz		
Tuning range	70 MHz		
Minimum RF Frequency Step	6.25 kHz		10 kHz @ 20 kHz spacing
Channel Bandwidth	12.5, 25, 50* kHz		*Ask for availability. ETSI EN 302 561 only
Frequency Stability	±0.5 ppm		-40°C...+85°C (Reference to +25°C)
Maximum Receiver Input Power without Damage	+3 dBm		
Maximum Receiver Input Power without Transmission Errors	-10 dBm		4FSK, 25 kHz, FEC ON
Sensitivity ²	typ. -113 dBm		4FSK, 25 kHz, FEC ON, BER = 10 ⁻²
	typ. -115 dBm		4FSK, 12.5 kHz, FEC ON, BER = 10 ⁻²
	typ. -112 dBm		8FSK, 25 kHz, FEC ON, BER = 10 ⁻²
	typ. -113 dBm		8FSK, 12.5 kHz, FEC ON, BER = 10 ⁻²
	typ. -104 dBm		16FSK, 25 kHz, FEC ON, BER = 10 ⁻²
	typ. -106 dBm		16FSK, 12.5 kHz, FEC ON, BER = 10 ⁻²
	typ. -17 dBm		4FSK, 25 kHz, FEC ON, BER = 10 ⁻²
	typ. -18 dBm		4FSK, 12.5 kHz, FEC ON, BER = 10 ⁻²
	typ. -18 dBm		8FSK, 25 kHz, FEC ON, BER = 10 ⁻²

Blocking ²	typ. -17 dBm		8FSK, 12.5 kHz, FEC ON, BER = 10 ⁻²
	typ. -29 dBm		16FSK, 25 kHz, FEC ON, BER = 10 ⁻²
	typ. -25 dBm		16FSK, 12.5 kHz, FEC ON, BER = 10 ⁻²
Intermodulation Response Rejection ²	typ. -37 dBm		4FSK, 25 kHz, FEC ON, BER = 10 ⁻²
	typ. -39 dBm		4FSK, 12.5 kHz, FEC ON, BER = 10 ⁻²
	typ. -36 dBm		8FSK, 25 kHz, FEC ON, BER = 10 ⁻²
	typ. -36 dBm		8FSK, 12.5 kHz, FEC ON, BER = 10 ⁻²
	typ. -44 dBm		16FSK, 25 kHz, FEC ON, BER = 10 ⁻²
	typ. -41 dBm		16FSK, 12.5 kHz, FEC ON, BER = 10 ⁻²
CO-Channel Rejection ²	typ. 8 dB		4FSK, 25 kHz, FEC ON, BER = 10 ⁻²
	typ. 11 dB		4FSK, 12.5 kHz, FEC ON, BER = 10 ⁻²
	typ. 10 dB		8FSK, 25 kHz, FEC ON, BER = 10 ⁻²
	typ. 11 dB		8FSK, 12.5 kHz, FEC ON, BER = 10 ⁻²
	typ. 21 dB		16FSK, 25 kHz, FEC ON, BER = 10 ⁻²
	typ. 20 dB		16FSK, 12.5 kHz, FEC ON, BER = 10 ⁻²
Adjacent Channel Selectivity ²	typ. -33 dBm		4FSK, 25 kHz, FEC ON, BER = 10 ⁻²
	typ. -45dBm		4FSK, 12.5 kHz, FEC ON, BER = 10 ⁻²
	typ. -34 dBm		8FSK, 25 kHz, FEC ON, BER = 10 ⁻²
	typ. -34 dBm		8FSK, 12.5 kHz, FEC ON, BER = 10 ⁻²
	typ. -43 dBm		16FSK, 25 kHz, FEC ON, BER = 10 ⁻²
	typ. -40 dBm		16FSK, 12.5 kHz, FEC ON, BER = 10 ⁻²
Spurious Rejection	typ. -39 dBm		4/8/16FSK, 12.5, 25, 50kHz, FEC ON
Transmitter Power		0.01, 0.02, 0.05, 0.1, 0.2, 0.5, 1 W	
Communication Mode	Half-Duplex		
Frequency Change Time	typ. 20 ms		Time required for switching from one RF frequency to another
TX to RX time RX to TX time	TBD		

Adjacent Channel Power		<-60 dBc	TX-mode, 12.5 kHz and 25 kHz. Acc. to EN 300 113 v2.2.1
Carrier power stability		< ±1.5 dB	During transmission.

	DATA MODULE	
Electrical Interface	CMOS-UART Inputs and outputs referred to IO Voltage processed by user (1.8-3.3V) RTS, CTS, RX, TX, +VCC, GND	
Interface Connector	1.27 mm pitch socket	Samtec 20-pin through hole, CLP-110-02-L-D-K-TR
Data speed of Serial interface	9600 – 115200 bps	
Data speed of Radio Air Interface	<u>4FSK FEC OFF / ON:</u> 19200 / 14400 bps (25 kHz) 9600 / 7200 bps (12.5 kHz) <u>8FSK FEC OFF / ON:</u> 28800 / 19200 bps (25 kHz) 14400 / 9600 bps (12.5 kHz) <u>16FSK FEC ON:</u> 28800 bps (25 kHz) 14400 bps (12.5 kHz)	
Air Interface Encryption	AES128, AES256	AES256 as an order option
Data Format	Asynchronous data	
Modulation	4-, 8-, 16FSK, GMSK	

	GENERAL	
Operating voltage	+3.8...+5.5 V	
Current consumption in Sleep1 mode	< typ. 510 mA	
Typical Power Consumption 403...473 MHz	Sync search typ. 0.95 W	RX-mode
	Receiving data typ. 0.94 mW	RX-mode
	SLEEP1: typ. 505 mW	RX-mode
	typ. 6.8 W @ 1 W RF out	TX-mode, Continuous, 50Ω, CHBW 25.0 kHz
	typ. 4.9 W @ 0.5 W RF out	
	typ. 3.6 W @ 0.2 W RF out	
	typ. 2.9 W @ 0.1 W RF out	
Inrush Current, DC voltage turned ON	< typ. 17 A, duration < typ. 9 μs	
Temperature Ranges	-20 °C ...+55 °C	Type Approval conditions
	-30 °C ...+70 °C	Functional
	-40 °C ...+85 °C	Storage
Vibration	≤ 25 G, up to 2 kHz sinusoidal	
ESD ³	± 10 kV	Antenna connector. Acc. to EN61000-4-2; 150 pF / 330 Ω
	± 8 kV	DTE connector. Acc. to EN61000-4-2; 150 pF / 330 Ω

Antenna Connector	50 Ω, HIROSE U.FL compatible	I-PEX 20279-001 -E-01
Construction	PWB with sheet metal EMI shields	
Size L x W x T	57 x 36 x 6.9 mm	See Appendix 10.2
Weight	20 g	

Test condition $V_{CC} = 4.2\text{ V}$ and $T_A = 25\text{ °C}$

¹Firmware rejects 405.925...406.176 MHz frequencies. The frequency band is reserved internationally for emergency transmitters as specified by FCC reference FCC 04-75.

²According to EN 300 113 V3.1.1 measurement setup.

³Measured under normal ambient conditions, $T_A = 25\text{ °C}$. When the device is used in different environment, the results may change significantly. It is recommended to use external ESD protection in demanding conditions.

2.5 Specifications, SATEL-TR489 (on 856 – 876 MHz)

	RECEIVER	TRANSMITTER	Note!
Frequency Range	856...876 MHz (869.400 ... 869.650 MHz*)		See chapter 10.1
Tuning range	20 MHz		
Minimum RF Frequency Step	6.25 kHz		
Channel Bandwidth	25 and 50 kHz		
Frequency Stability	<1 kHz		
Maximum Receiver Input Power without Damage	+14 dBm		
Maximum Receiver Input Power without Transmission Errors	-10 dBm		FEC ON
Sensitivity ¹	25 kHz -110dBm 50 kHz -103dBm		FEC ON
Blocking ¹	> 82 dB @ 1 MHz offset > 83 dB @ 2 MHz offset > 85 dB @ 5 MHz offset		FEC ON
Intermodulation Attenuation	typ. > 57 dB		FEC ON
CO-Channel Rejection	typ. > -17dB		FEC ON
Adjacent Channel Selectivity ¹	> 60 dB		FEC ON
Spurious Rejection	typ. > 70 dB		FEC ON
Transmitter Power (856...876 MHz)		0.01, 0.02, 0.05, 0.1, 0.2, 0.5 W	
Communication Mode	Half-Duplex		
Frequency Change Time	typ. 40 ms		Time required for switching from one RF frequency to another

TX to RX time RX to TX time	typ. 4 ms		
Adjacent Channel Power		acc. to EN 300 220 -1	TX-mode
Transient Adjacent Channel Power		acc. to EN 300 220 -1	TX-mode
Carrier power stability		< ±1.5 dB	

DATA MODULE		
Electrical Interface	CMOS-UART Inputs and outputs referred to IO Voltage processed by user (1.8-3.3V) RTS, CTS, RX, TX, +VCC, GND	
Interface Connector	1.27 mm pitch socket	Samtec 20-pin through hole, CLP-110-02-L-D-K- TR
Data speed of Serial interface	9600 – 115200 bps	
Data speed of Radio Air Interface	4FSK FEC OFF / ON: 19200 / 14400 bps (25 kHz) 38400 / 28800 bps (50 kHz)	
Air Interface Encryption	AES128, AES256	AES256 as an order option
Data Format	Asynchronous data	
Modulation	4FSK	

GENERAL		
Operating voltage	+3.8 ... +5.5 V	
Current consumption in Power Save mode	< 2 mA	ENA_MOD set to LOW
Maximum DC Ripple Voltage ²	max. 100 mV _{pp}	0 < f ≤ 15 kHz
	max. 130 mV _{pp}	15 kHz < f ≤ 20 kHz
	max. 150 mV _{pp}	f > 20 kHz
Typical Power Consumption	0.96 W	RX-mode
	SLEEP1: 0.26 W	RX-mode
	5.6 W @ 0.5 W RF out	TX-mode Continuous 50 Ω
	3.6 W @ 0.2 W RF out	
	3.2 W @ 0.1 W RF out	
	2.8 W @ 0.05 W RF out	
	2.7 W @ 0.02 W RF out	
2.6 W @ 0.01 W RF out		
Inrush Current, power turned ON ³	< 12 A, duration < 50 μs	RX-mode
Temperature Range	-20 °C ... +55 °C	Type Approval conditions
Temperature Ranges	-30 °C ... +70 °C	Functional
	-40 °C ... +80 °C	Storage
Vibration	≤ 25 G, up to 2 kHz sinusoidal	MIL-STD-202G Test condition D MIL-STD-202G Test condition F MIL-STD-202H-213
	± 10 kV	Antenna connector. Acc. to EN61000-4-2; 150pF/330Ω

ESD ⁴	± 8 kV	DTE connector. Acc. to EN61000-4-2; 150pF/330Ω
Antenna Connector	50 Ω, HIROSE U.FL compatible	I-PEX 20279-001 -E-01
Construction	PWB with sheet metal EMI shields	
Size L x W x T	57 x 36 x 6.9 mm	
Weight	20 g	

*) Tested acc. to EN 300 220-1 V.3.1.1, EN 300 220-2 V3.2.1 (4FSK, 25 kHz / 50 kHz).

Nominal operating frequency: 25 kHz channel width @ 869.4125...869.6375 MHz / 50 kHz channel width @ 869.4250...869.6250 MHz

Test condition $V_{CC} = 4.0 \text{ V}$ and $T_A = 25 \text{ °C}$

¹ According to EN 300 220-1 measurement setup.

² Higher values exceed the -36 dBm spurious limit at the antenna e.g. EN 300 220-1 V.3.1.1 requirement.

³ Measured using Agilent 1147B current probe and TTI TSX1820P DC power supply.

⁴ Measured under normal ambient conditions, $T_A = 25 \text{ °C}$. When the device is used in different environment, the results may change significantly. It is recommended to use external ESD protection in demanding conditions.

2.6 Specifications, SATEL-TR489 (on 902 – 928 MHz)

	RECEIVER	TRANSMITTER	Note!
Frequency Range	902-928 MHz		
Spreading Method	Frequency Hopping		
Occupied Bandwidth	230 kHz		
Frequency Stability	<1 kHz		
Maximum Receiver Input Power without Damage	+10 dBm		
Maximum Receiver Input Power without Transmission Errors	-3 dBm		
Sensitivity	typ. -109 dBm for BER 10^{-4}		
Transmitter Power		0.01, 0.02, 0.05, 0.1, 0.2, 0.5, 1 W	
Carrier power stability		< ±1.5 dB	
Data Rate	115.2 kbit/s		
Modulation Method	2-GFSK		
Hopping Bands	7, user selectable		
Hopping Patterns	15 per band, 105 total, user selectable		
Hopping Channels	50-112, user selectable		
Frequency Zones	16 Zones, 7 Channels per Zone		
Temperature Ranges	-20 °C ...+55 °C		Type Approval conditions
	-30 °C ...+70 °C		Functional
	-40 °C ...+85 °C		Storage
Operating Voltage	+3.8 ... +5.5 V		
Power Consumption	0.42 W (Receive mode) 4.3 W (Transmit Mode 1W)		

Vibration	≤ 25 G, up to 2 kHz sinusoidal	MIL-STD-202G Test condition D MIL-STD-202G Test condition F MIL-STD-202H-213
ESD ⁴	± 10 kV	Antenna connector. Acc. to EN61000-4-2; 150pF/330Ω
	± 8 kV	DTE connector. Acc. to EN61000-4-2; 150pF/330Ω
Antenna Connector	50 Ω, HIROSE U.FL compatible	I-PEX 20279-001 - E-01
Construction	PWB with sheet metal EMI shields	
Size L x W x T	57 x 36 x 6.9 mm	
Weight	20 g	
Electrical Interface	CMOS-UART Inputs and outputs referred to IO Voltage processed by user (1.8-3.3V) RTS, CTS, RX, TX, +VCC, GND	USB interface in use
Interface Connector	1.27 mm pitch socket	Samtec 20-pin through hole, CLP-110-02-L-D-K- TR
Data speed of Serial interface	9600 – 115200 bps	

⁴Measured under normal ambient conditions, T_A = 25 °C. When the device is used in different environment, the results may change significantly. It is recommended to use external ESD protection in demanding conditions.

3 TIME PARAMETERS FOR STARTUP AND SHUTDOWN SEQUENCES

The following table shows the recommend times for startup and shutdown sequences.

Parameter	Recom. Time (*)	Explanation
$t_{vccin-ena}$	>2 ms	VCC_IN must be high before ENA_MOD is high
$t_{enamod-io}$	>2 ms	ENA_MOD must be high before VCC_IO is high
$t_{enamod-cts}$	$100\text{ ms} < t_{enamod-cts} < 500\text{ ms}$	CTS ready settling time
$t_{vccio-cts}$	>2 ms	VCC_IO must be high before CTS is ready
$t_{vccio-gpio}$	>2 ms	VCC_IO must be high before GPIO PINS are active
$t_{gpio-cts}$	>0 ms	GPIOs must be active before CTS is ready
$t_{enamod-gpio}$	>80 ms	Input pins must be low after ENA MOD is low
$t_{gpio-vccio}$	>0 ms	GPIOs must be low before VCC_IO is low
$t_{vccio-vccin}$	>0 ms	VCC_IO must be low before VCC is low

3.1 Startup sequence

The following diagram will describe the startup sequence.

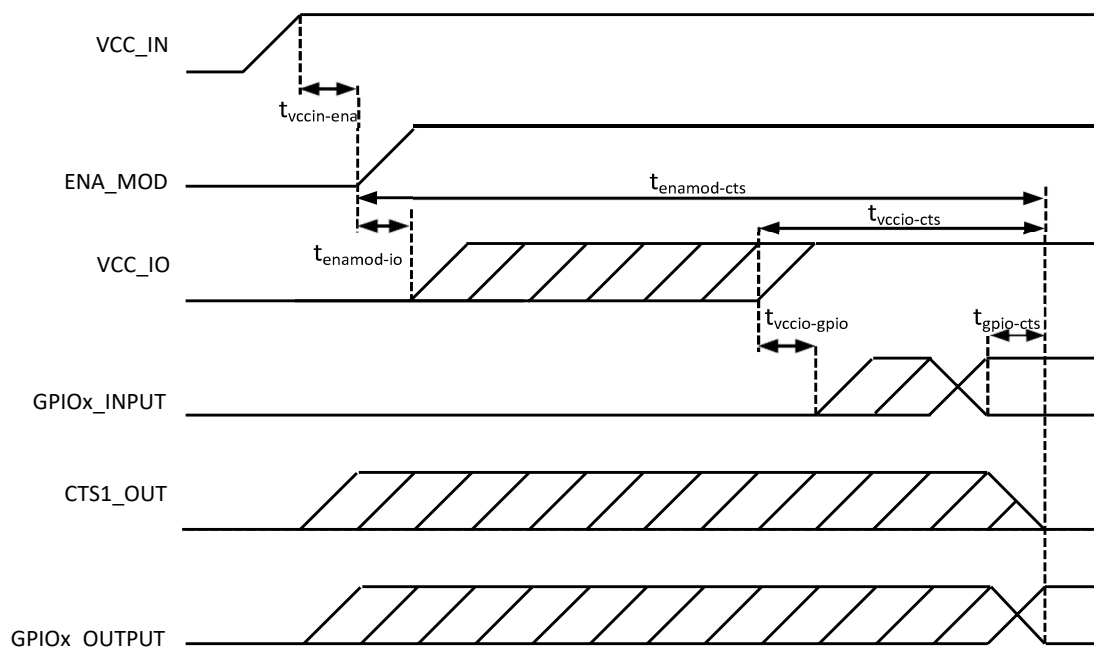

Figure 3.1 Startup sequence.

3.2 Shutdown and ENA sequences

The following diagrams will describe the shutdown and ENA sequences.

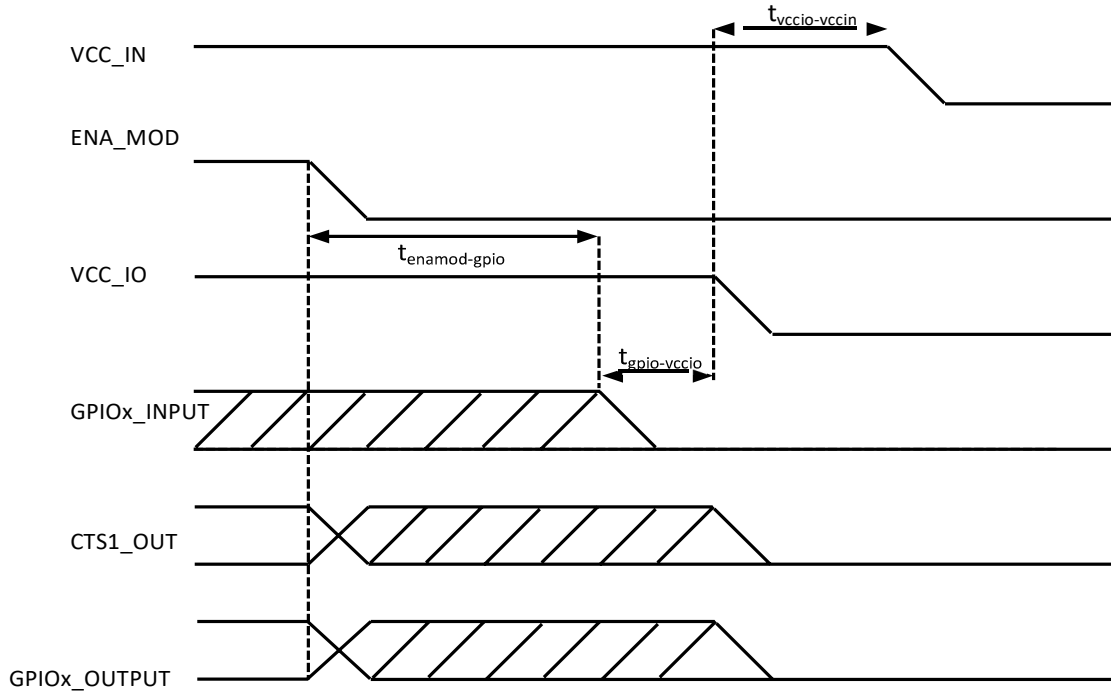

Figure 3.2 Shutdown sequence.

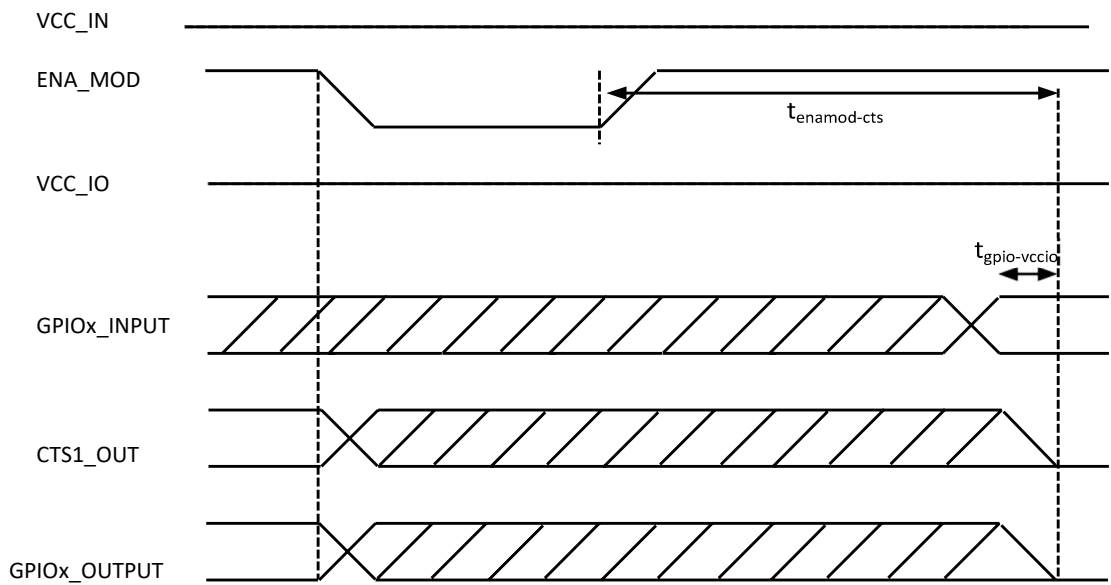

Figure 3.3 ENA sequence.

4 ELECTRICAL INTERCONNECTION

4.1 DTE connector

The DTE connector is a 20-pin pass-through connector. Connector is female two row 1.27 mm pitch. This connector allows the pin to enter the connector from the bottom side and protrude thru the module PCB to the top side, allowing flexible mounting heights with various pin lengths. Alternative DTE connector assembly variants available. DTE connector assembled either BOTTOM or TOP side of the module.

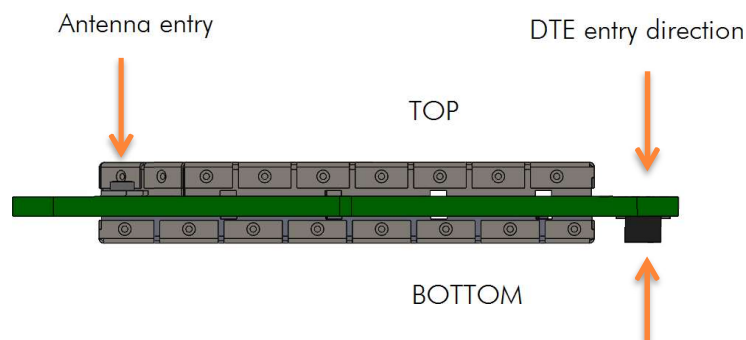

Figure 4.1 The side view of the module with connection directions.

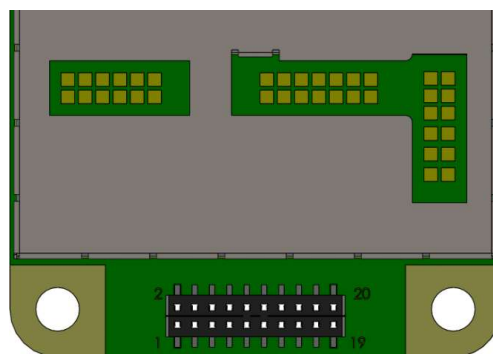

Figure 4.2 Pin numbering of 1.27 mm pitch DTE connector. View from bottom side of unit.

4.2 Pin order of the DTE connector

Direction IN is data from DTE (Data Terminal Equipment) to the radio transceiver module.
Direction OUT is data from the radio module to the DTE.

The equivalent I/O schematic figures are shown in the next chapter.

Pin No.	Equivalent I/O Schematic	Signal name	Type	Direction	Pin State	Description
1,2	Figure 1	VCC_IN	POWER	IN	External Voltage	DC input
3,4	-	GND	GND	-	External Ground	Ground reference for power and signals
5	Figure 2	VCC_IO	POWER	IN	External Voltage	Device IO driver input
6	Figure 7	ENA_MOD	IO	IN	Internal Pull Down	Module ENA pin
7	Figure 3	RD1	CMOS	OUT	Output Driver	Receive data, active low.
8	Figure 3	CTS1	CMOS	OUT	Output Driver	Clear To Send, active low.
9	Figure 6	TD1	CMOS	IN	Internal Pull Up	Transmit Data, active low.
10	Figure 6	RTS1	CMOS	IN	Internal Pull Up	Ready to send, active low.
11	Figure 4	GPIO1	CMOS	OUT	Internal Pull Down	*)
12	Figure 4	GPIO2	CMOS	OUT	Internal Pull Down	*)
13	Figure 6	GPIO3	CMOS	IN	Internal Pull Up	*)
14	Figure 6	GPIO4	CMOS	IN	Internal Pull Up	*)
15	Figure 5	STAT	CMOS	OUT	Output Driver	Various sequences (section 4.7).
16	Figure 6	GPIO5	CMOS	IN	Internal Pull Up	*)
17	Figure 6	SERVICE	CMOS	IN	Internal Pull Up	Input for service access, active low. See separate section of the manual (section 4.6).
18	Figure 4	GPIO6	CMOS	OUT	Internal Pull Down	*)
19	Figure 4	GPIO7	CMOS	OUT	Internal Pull Down	*)
20	Figure 4	GPIO8	CMOS	OUT	Internal Pull Down	*)

*) See separate document. https://www.satel.com/wp-content/uploads/2021/10/TIL-0026_SATEL-Radio-Modules_GPIO-Interface.pdf

4.3 Equivalent I/O Schematics

The module input-output equivalent circuits are shown in the figure and the component values in the table below.

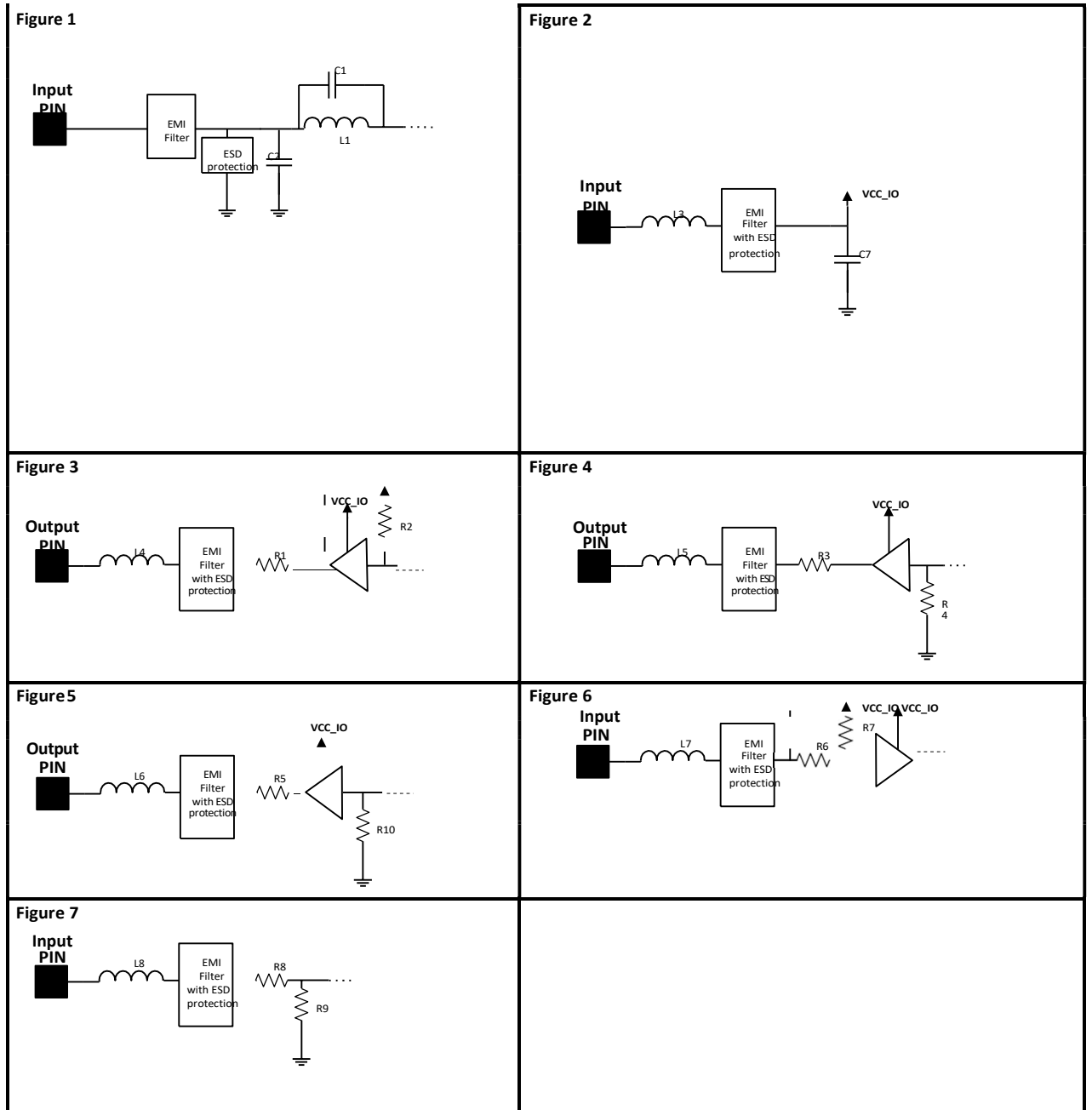

Figure 4.3 The module input-output equivalent circuits.

Component values of the equivalent schematics:

Component	Value	Note
C1	6.8 pF	
C2	1 uF	
L1	220 nH	
L3	1000 Ω +- 25%	Measured Impedance at 100 MHz
C7	100 nF	
L4	1000 Ω +- 25%	Measured Impedance at 100 MHz
R1	330 Ω	
R2	100 k Ω	
L5	1000 Ω +- 25%	Measured Impedance at 100 MHz
R3	330 Ω	
R4	100 k Ω	
L6	1000 Ω +- 25%	Measured Impedance at 100 MHz
R5	330 Ω	
L7	1000 Ω +- 25%	Measured Impedance at 100 MHz
R6	330 Ω	
R7	100 k Ω	
L8	1000 Ω +- 25%	Measured Impedance at 100 MHz
R8	1 k Ω	
R9	>1 M Ω	
R10	100 k Ω	

4.4 **RF interface**

The antenna interface is a 50 Ω coaxial connector. Matching networks are not included on the module and should be placed in the host application if the antenna is not 50 Ω . The HIROSE U.FL compatible connector is located on the TOP side of the board.

NOTE! The used connector has gold plated contacts - whereas a standard HIROSE U-FL has silver plated contacts.

If silver - gold joints are not allowed in your product, use gold plated cable-connector to mate to this device.

NOTE!

Setting the transmitter output power to such a level that exceeds the regulations set forth by local authorities is strictly forbidden. The setting and/or using of non-approved power levels may lead to prosecution. SATEL and its distributors are not responsible for any illegal use of its radio equipment, and are not responsible in any way of any claims or penalties arising from the operation of its radio equipment in ways contradictory to local regulations and/or requirements and/or laws.

4.5 VCC_IO pin

VCC_IO pin determines the voltage level of UART signals and the voltage level of GPIO output signals. VCC_IO level also determines GPIO LOW/HIGH levels on each GPIO and UART input pins.

4.6 Service pin

The SERVICE pin is used to set the UART1 into a known state. Pulling this pin LOW will activate the service mode and set the UART1 into 38400, 8, N, 1. This is intended for service access of the module, to have a known serial port setting in order to provide easy access to module settings.

The pin does not affect any permanent settings, nor does it change the mode of the module. It is recommended to pull high or pull up by resistor to VCC_IO to return serial port 1 into the configured state. When service pin is LOW the SL Commands are temporary forced to be ON

4.7 Stat pin

The STAT-pin indicates the status of the device. It can be used to drive or sink a LED current using a proper series resistor. STAT-pin drive or sink capability is +/-10mA at 3.3V. It is recommended to use VCC_IO for LED current.

Notice that if STAT-pin is used to sink LED current, LED behavior is opposite to driving scheme. The behavior of the STAT pin is described down below.

Modes of STAT pin:

Blink cycle	Mode
"1" - statically	Module is operational "searching for a new frame"
"0" for the endurance of the received frame.	"0" when module is receiving data from air interface. In practical cases will toggle at the frequency of the data packets on the air interface.
"0" statically	Module is in sleep1 mode
The pin is toggled in transmission interval	Module is sending data Over the Air
Pin is toggled in 1 s interval	Module has the connection to SATEL Configuration Manager program.
Pin is toggled in 500 ms interval	SL command mode set to OFF and SL commands enabled using "+++" sequence, section 7.2.
Pin is toggled in 250 ms interval	Module has detected a fault, fault codes can be read via SATEL Configuration Manager program.

4.8 VCC pins

VCC pins are to feed operating voltage to the module. Limit for this voltage is mentioned in chapter 2.2 DC electrical specifications. User must take into consideration surge current and current consumption issues before using these pins. Also the user must be aware for any voltage drop on the feeding path.

4.9 UART pins

Pins 7, 8, 9, 10 are used for UART serial transmission between the module and the terminal. The UART signal level corresponds to the level in VCC_IO pin. VCC_IO pin must be fed with a correct voltage level to match the terminal device.

4.10 GPIO pins

See separate document:

https://www.satel.com/wp-content/uploads/2021/10/TIL-0026_SATEL-Radio-Modules_GPIO-Interface.pdf

Unused pins should be left unconnected.

5 MECHANICAL CONSIDERATIONS

5.1 Fixing device to host

The radio transceiver module can be mounted on to the host application by using spacers and screws. It is highly recommended to use conducting metal spacers and screws to create proper electrical conductivity between the module and the host application. Recommended materials for spacers include brass or aluminum and steel screws. User must take care that there is no excessive mechanical stress created to the DTE connector while inserting and attaching the module. Recommended maximum screw size is M3, minimum spacer height between the module and the host application is 3 mm.

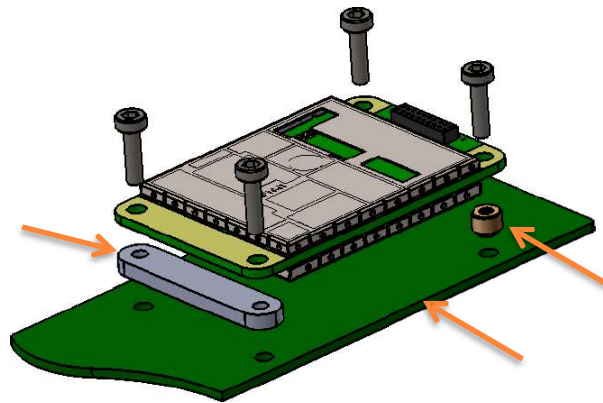
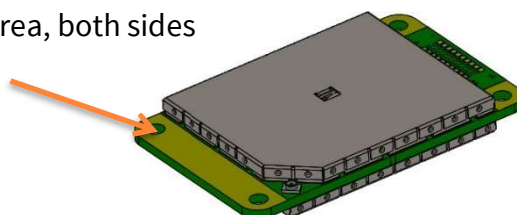

Figure 5.1 Example of module attachment to application PCB.

5.2 Heat transfer

Since the module creates heat while operating, it must take into consideration to maximize the heat transfer from the module to an external heat sink. Proper heat sinking methods could be copper plated PCB, metal housing or a heat sink piece. The most recommended solution is to use a metal conductor to transfer heat from the module to an external heat sink which dimensions and location is adequate for a proper performance. To source the heat from the module is the plain area next to the antenna connector shown in a figure 5.2. Heat can be conducted from either side. To further improve the heat conductivity and reducing the heat transfer barriers, proper heat conducting paste or heat conducting tape should be used.

Figure 5.2 Heat sourcing area, both sides



6 OPERATING MODES

The radio transceiver module has the following modes of operation:

MODE	FUNCTION	DESCRIPTION
Ready to receive from RF	Search for sync	Module is searching for the start of a radio transmission from the RF signal.
	Receive data	The module has found a valid radio transmission and is receiving data.
TX	Transmit	The module transmits
Safe mode		Mode is entered when a fault has been detected and the device has been Rebooted. In safe mode fault codes can be read from the module (section 6.1).
Sleep mode	Sleep1	Will turn the module into a state where it will hold parts of the radio on, wakeup will take approx. 30 ms
Power Save mode	Power save	Automatic sleep/wake-up procedure where module sleeping time is dynamically adjusted to received data packets. Decreases the power consumption of complete receiving cycle approx. 30%.

6.1 Switching frequency band

SATEL-TR489 totally contains three different frequency Bands which are user selectable. Only one frequency band can be active at the time, which means that all user configurations are targeting at the selected band. Selection of active frequency band can be done with SATEL configuration manager or using SL commands.

When using SL commands, command mode usage is recommended. Sequence is as follows:

- Enter command mode (See section 7.2 - SL Command Mode)
- Switch frequency band using SL Command
- Save Settings
- Reboot modem using SL Command or power cycle. Note that Command mode exit sequence is not required as after reboot device is in normal data mode.

SL commands are described in separate documentation. In order to get information of the latest and/or special SL commands please contact local SATEL distributor or SATEL:

<https://www.satel.com/where-to-buy/>.

6.2 Safe mode

When a fault has been detected by the Firmware, the module is set to Safe mode. In this mode the module toggles the STAT pin in 250 ms interval indicating an Error and reboots the device after 5 s. Transmitting/Receiving is prohibited during malfunction. When connecting to the device with SATEL Configuration Manager the Error code is shown in pop up box. If the device does not recover after multiple reboots, please contact SATEL Oy.

SATEL Configuration Manager can be downloaded from website <https://www.satel.com/support-and-services/downloads/>. The version 1.16.7 or newer is compatible with SATEL-TR489 radio transceiver module.

6.3 Power up / power down scenarios

The transceiver module can be set in four (4) states, “ON”, “OFF”, “Sleep1” and “Power Save”. When power is applied to the module, the module switches to ON state when voltage in ENA_MOD is set to HIGH.

The module can be shut down by driving ENA_MOD line to LOW state. In the “OFF” state current consumption is only that of leakage current from an LDO, section 2.3. In this state all non-essential parts of the module are powered down and all settings/state information that are not stored in nonvolatile memory are reset.

6.4 Sleep Mode

When being in sleep mode, the radio part of the module is switched OFF while the serial interface communication related parts remain powered ON. The module will be automatically woken up after the CPU senses a state change in the TD1 pin. *Example:* The module is in Sleep1- mode. The module is woken up by sending a character or characters into the TD1 pin after which the module responds “OK”. After “OK” the module is ready for normal communication.

To turn the module ON from Sleep1 mode:

- 1) Issue a state change to TD1 (toggle pin (minimum pulse duration time 10 μ s) or issue a byte on the UART (for example 0x00))
- 2) Wait for “OK” -response from the module. The wake-up time is approx. 30 ms.
- 3) Start communicating normally

Module will remain powered ON until a new sleep command is issued.

6.5 **Power Save Mode**

The Power save mode performs an automatic, self-adjusting receiver wake-up/sleep cycle. It is designed for applications which base on one-way communication with relatively constant TX interval and, in which the data packet separation is > 200 ms.

When enabled, the unit makes the *transmission interval study* basing on four (4) successfully received data packets. The shortest time between transmitted packets is measured (t_{min}). Measured value is updated after each successfully received data packet, so that possible changes in the message length becomes noted.

Ensuring that the complete messages will be received even if there occur little variation in transmission interval, some safety margin (t_{marg}) is left into Ready to receive from RF mode time.

Safety margin is calculated by dividing the shortest time between transmitted packets (t_{min} , in ms) with 8 and by adding 60 ms to this result:

$$t_{marg} = \frac{t_{min}}{8} + 60 \text{ ms}$$

The length of the whole sleeping period (t_{sleep}) is calculated by decreasing the shortest time between transmitted packets (t_{min}) with safety margin (t_{marg}) and transmission time of the original message (t_{TX}):

$$t_{sleep} = t_{min} - t_{marg} - t_{TX}$$

Transmission interval study is started over always after 100 successful sleep/wake-up cycles and, if the expected receiving slot ($t_{RX \text{ slot}}$) with enhanced overlap margin ($t_{overlap}$) has been missed. In latter case the package is considered to be lost.

$$t_{overlap} = t_{marg} + 100 \text{ ms}$$

$$t_{RX \text{ slot}, min} = t_{min} - t_{marg}$$

$$t_{RX \text{ slot}, max} = t_{min} + t_{overlap}$$

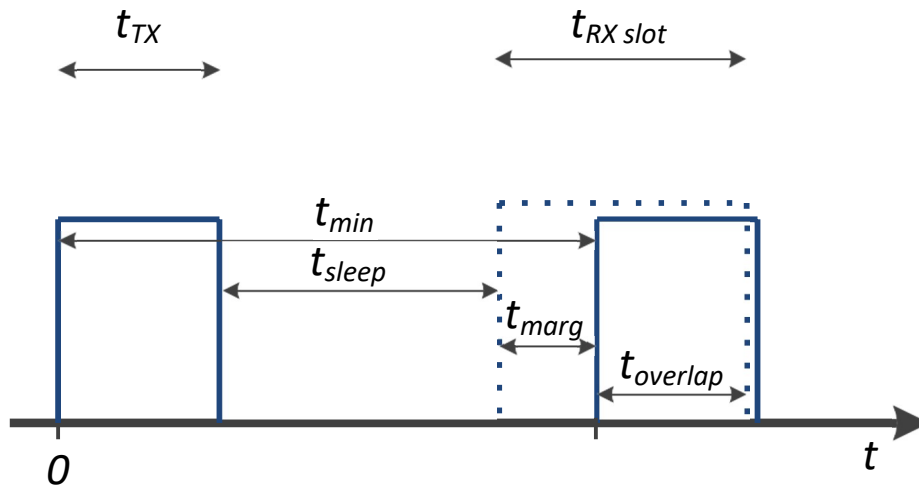

Figure 6.1 Power save mode timing factors.

E.g. In system with TX interval of 1 s, and with 300 ms (approx. 300B @ 9600 bps) transmission time:

$$t_{min} = 1000 \text{ ms} \quad t_{TX} = 300 \text{ ms}$$

$$t_{marg} = 125 \text{ ms} + 60 \text{ ms} = 185 \text{ ms}$$

$$t_{sleep} = 1000 \text{ ms} - (125 \text{ ms} + 60 \text{ ms}) - 300 \text{ ms} = 515 \text{ ms}$$

$$t_{RX \text{ slot}, min} = 1000 \text{ ms} - 185 \text{ ms} = 815 \text{ ms} \quad t_{RX \text{ slot},$$

$$max = 1000 \text{ ms} + 185 \text{ ms} = 1185 \text{ ms}$$

6.6 Restart

After startup the module can be restarted by issuing a SL command, upon which the module will shut down all circuitry, and Reboot the CPU (see SL command list).

7 CHANGING PARAMETERS USING SL COMMANDS

The controlling terminal device can change the configuration settings of the module. This is accomplished with the help of SL commands. SL commands can be used to change e.g. the frequency or addresses. It is also possible to ask the radio transceiver module to show current settings which are in use.

7.1 SL Commands

The controlling terminal device can change the configuration settings of a radio. This is accomplished with the help of SL commands, which can be used during data transfer. SL commands can be used to change e.g. the frequency or addresses. It is also possible to interrogate a radio modem in order to gain information concerning current settings that are in use. SL command -setting must be enabled before they can be used.

An SL command is a continuous string of characters, which is separated from other data by pauses which are equal or greater than time defined by Pause length parameter (default=3 characters) in the set-up. No extra characters are allowed at the end of an SL command.

Serial interface settings are the same as in data transfer. SL command is properly recognized also in the case when the command string is terminated by <CR> (=ASCII character no. 13, Carriage Return, 0x0d) or <CR><LF> (<LF> = ASCII char. no. 10, Line Feed, 0x0a). If multiple SL commands are sent to the module, the next command can be given after receiving the response ("OK" or "ERROR") of the proceeding command. In addition, it is recommended to implement a timeout to the terminal software for recovering the case when no response is received from the radio module.

The transceiver module will acknowledge all commands by returning an "OK" (command carried out or accepted) or the requested value, or an "ERROR" (command not carried out or interpreted as erroneous) message.

It is possible to use SL commands in Port 2 (TD2 signal in GPIO3 (Pin13) and RD2 signal in GPIO1 (Pin11)) when Port2 Function has been configured as Diagnostics. SL commands can be used even in parallel with Port1 – in that case the response appears in the same port where the SL command came from.

Port2 is configured on Serial Interface sheet of SATEL Configuration Manager software by selecting the Port2 Function:

- OFF (=Port 2 not in use)
- Diagnostics (=SL commands ON in this case)

CR/LF characters are added to end the response messages (unless they are already present) in order to make parsing easier. Settings can be toggled, SL Commands ON/OFF, CR/LF ON/OFF.

SL commands are described in separate documentation. In order to get information of the latest and/or special SL commands please contact local SATEL distributor or SATEL:

<https://www.satel.com/where-to-buy/>.

7.2 SL Command Mode

The SL commands have always been enabled in the previous products like M3-R3. When the SL commands are enabled there are possibilities that the user data may start with the characters “SL” which is handled as the SL command. This has caused the firmware to go to the continuous SL command search mode and any data has not been sent or even an “ERROR” acknowledgment has been received. To avoid this kind behavior the user can disable the SL commands.

The SL commands can be disabled or enabled by using SL commands or toggling the “*SL Command mode*” parameter via the *SATEL Configuration Manager*, version v1.16.7 or newer.

By default the *SL Command mode* is set to ON. If the *SL Command mode* is set to OFF then the SL commands can be enabled or disabled by using the below described procedure. Regardless of original SL command –setting state, changing the setting state with this procedure will effect to the reception process of the radio module. SL command –setting state can be changed only via SATEL Configuration Manager in maintenance access level.

Note1

To enable the SL Commands* (disables interface transmission and reception):

- Send three “+” characters via serial port so that there is at least three bytes delay between each character. The response is “OK”, when successfully set.
<+><at least three bytes pause><+><at least three bytes pause><+>

To disable the SL Commands* (enables radio interface transmission and reception):

- Send three “-” characters via serial port so that there is at least three bytes delay between each character. The response is “OK”, when successfully set.
<-><at least three bytes pause><-><at least three bytes pause><->

*) Regardless of the set state for the SL command mode.

Note2

The “+ + +” and “- - -” procedures are not allowed to be used, when radio is transmitting or receiving data (i.e. the application data occupies the TD or RD lines of the radio).

Note 3

900MHz frequency band parameters set via SL commands require device restart for the new parameters to be taken into use. The device reset is performed during exiting the command mode (---).

8 DEFAULT DELIVERY VALUES – SATEL-TR489

DEFAULT VALUES OF THE USER ADJUSTABLE SETTINGS		
Setting	Default value	Range
Radio frequency		
Operating TX and RX frequency	438.000 MHz	403 - 473 MHz
Channel Spacing (equals channel width)	12.5 kHz	12.5 kHz, 25 kHz
Transmitter Output Power	1 W	0.01, 0.02, 0.05, 0.1, 0.2, 0.5 and 1 W
Radio settings		
Radio Compatibility	SATEL 3AS	SATELLINE-3AS PacCrest-4FSK PacCrest-GMSK PacCrest-FST TrimTalk450s(P) TrimTalk450s(T) SATELLINE-2ASxE* SATEL-8FSK-1 (FEC OFF) SATEL-8FSK-2 (FEC ON) SATEL-16FSK-1 (FEC ON)
Addressing		
RX Address	OFF	ON/OFF
TX Address	OFF	ON/OFF
Serial port		
Data speed	115200 bps	1200 -115200 bps
Data bits	8	8
Parity bits	None	None, Even, Odd
Stop bits	1	1
Handshaking		Handshaking lines apply to the DATA-port
CTS	TX Buffer State	Clear to send, TX Buffer State
RTS	Ignored	Ignored, Flow Control
Additional setup		
Error Correction, FEC	OFF	ON/OFF
Error check	OFF	OFF, CRC8Partial, CRC8Full, CRC16Full
SL Command Mode	ON	ON/OFF
Repeater Mode	OFF	ON/OFF
TX Delay	0	0 65535 ms
Over-the-Air-Encryption	OFF	ON/OFF
Use Channel List	OFF	ON/OFF
Power Save Mode	OFF	ON/OFF
Add RSSI to Data	OFF	ON/OFF
Radio state	Tx/Rx	Tx/Rx / Rx (transceiver modules)

*Ask availability

9 CONSIDERATIONS

9.1 EMI Interferers

The module is designed to be mounted inside a host device. The module is designed to withstand EMI even beyond type approval requirements. However, a small module which is integrated closely to modern high speed electronics is bound to receive some interference.

To make a working integration, consider the following: EMI can enter the module in four ways:

- 1) Via the antenna (radiation from enclosure enters the antenna)
- 2) Radiated disturbances to the coaxial cable
- 3) Radiation from other electronics / cabling directly to the module
- 4) Conducting through the DTE interface (power, control and data lines).

Because the module is shielded and the DTE interface is filtered, the usually worst method of disturbance is via the antenna port, which is easily overlooked in design. Keep in mind that the radio module has a sensitivity of approx. -115 dBm (depends on mode of operation and speed etc.). While the module has an approx. 10 dB S/N requirement, this constitutes, that any signal entering the radio antenna on receive frequency on a level of < -125 dBm (-115 dBm -10 dB), causes desensitization of the radio on that particular channel.

Example:

An interferer has a level of -100 dBm on the frequency 421 MHz. The radio will show an approximate sensitivity of -90 dB (-100 dBm + S/N requirement 10 dB) on 421 MHz.

Now consider that generic EMC requirements usually have pass/fail criteria of -57dBm (if normalized to the surface of the device). So there is almost a 70dB gap between generic EMC requirements and co-existence requirements between a high sensitivity narrowband radios.

To avoid problems of co-existence a good design should apply:

- 1) EMI shielding in enclosure – ambient air interface
- 2) careful layout
- 3) shielding of all digital high speed parts and cables
- 4) Have a clocking plan to avoid clock frequencies causing harmonics on the UHF band of interest.

Number one is to recognize this challenge and act upon it.

SATEL R&D can help in this by participating in design review of the host device, aiming to catch problems early in the design phase.

9.2 Electrostatic discharge

As the module is intended to be embedded in a host application, in a typical use case, the antenna port is the only port of the module directly interface with a surface or contact area subjected to Electrostatic Discharge (ESD). Thus, the antenna port is the only interface with high level ESD protection. The DTE port also features ESD protection diodes, but is not designed to withstand similar performance as expected from standalone units with enclosures.

Consequently, the module should be subject to ESD handling precautions that typically apply to ESD sensitive components. Proper ESD handling and packaging procedures must be applied throughout the processing, handling and operation of any application that incorporates this module.

9.3 Using the device in unmanned high reliability applications

The module features software and hardware watchdogs which are incorporated inside the CPU. While we believe that this is a reliable method of keeping the module in operational condition, there are parts of the module that can't be monitored for proper operation to 100%. For example the module chip has a firmware that resides in the chips RAM. The firmware can't be read back or reloaded, without interrupting reception. Hence the module can't reload this automatically by itself without causing breaks in communication. To avoid the module from ending up in a state where for example the module chip firmware is corrupted for example by ionizing radiation, it is recommended that the controlling system implements some form of watchdog function for the module. This can be done for example if the system knows that data should be received every second, and no data has been received for a minute – then do a module restart using the ENA_MOD pin or by issuing a restart command, or a cold boot by toggling VCC_IN low and high again.

9.4 Proposals for more reliable radio link

In case where the environment is challenging the following methods can be used for improving the transmission reliability:

- Forward Error Correction, FEC, is recommend to use in challenging environment like urban areas.
- Directional antennas.
- Before building the radio link(s) it is highly recommend that the radio environment is measured to find out whether the radio environment is clean enough by using a spectrum analyzer or radio module's RSSI, Received Signal Strength Indication,value.
- Co-operation with the local authority to find out the optimum free radio channel.
- If the channel is disturbed an external band-pass filter can be used for improving the filtering.
- If at the adjacent channel is TDMA, Time Domain Multiple Access, it is recommended to use time slot for receiving which is not in synchronization with the TDMA radio transmission.
- In Europe it is not recommended to use channels which are located near by the TETRA or television frequencies.

10 APPENDIX

10.1 Sub-band Channel Assignment – SATEL-TR489

Note! Supported only with 800 MHz band

Sub-band

Each sub-band is defined by a start and stop frequency. Furthermore, the maximum allowed power level and maximum duty cycle is defined separately for each sub-band.

Duty cycle

The purpose of the duty cycle limit is to ensure that no single application can occupy this license-free band for more than a certain percentage of time. The term duty cycle defines the percentage of a 1-hour period a single modem is allowed to transmit. The modem limits the duty cycle itself.

Power level

The power level limit is defined separately for each sub-band. The maximum power limit for each sub-band is pre-programmed into the SATEL-TR489. The user can choose from 10, 20, 50, 100, 200 and 500 mW ERP* output power for frequency variant 856...876 MHz. No matter what power level the user has chosen the maximum allowed power level of the chosen sub-band cannot be exceeded.

*ERP = The effective radiated power from the antenna relative to a half-wave dipole in a certain direction

Channel assignment

Each sub-band is divided into 25 kHz channels according to a channel assignment scheme defined by the recommendation CEPT/ERC/REC 70-03.

10.2 Module dimensions

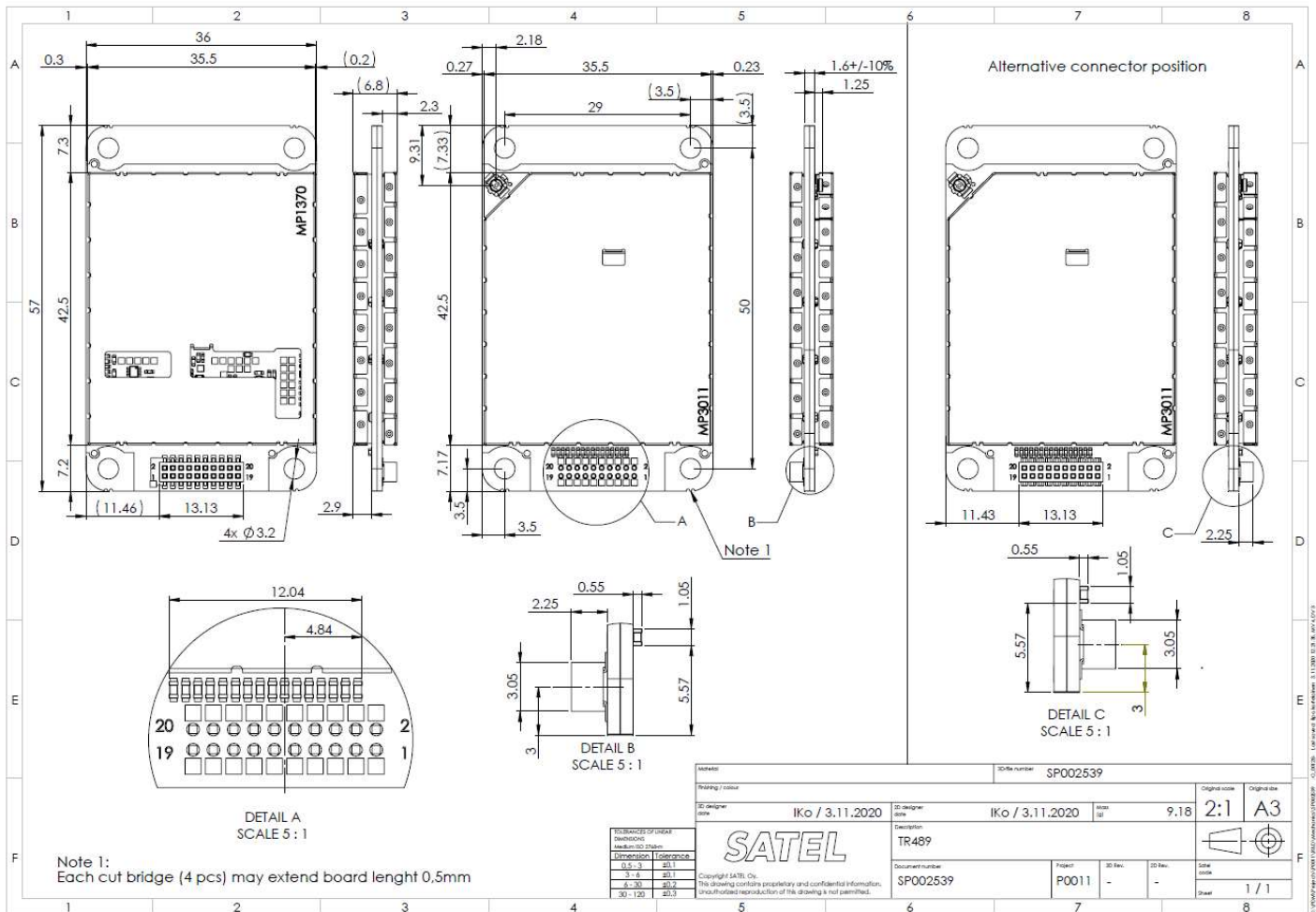

10.3 SL commands list

SL commands are described in separate documentation. In order to get information of the latest and/or special SL commands please contact local SATEL distributor or SATEL:

<https://www.satel.com/where-to-buy/>.

11 VERSION HISTORY

Version:	Date:	Remarks:
0.1	04.12.2020	First Draft
0.1	17.12.2020	First Draft updated
0.2	01.03.2021	RF-parameters updated
0.3	03.03.2021	Value list updated
0.4	03.03.2021	Added chapter 6.1 Switching frequency band
0.5	05.03.2021	Added ANNEX: SL-command List
0.6	12.11.2021	Added ANNEX: Sub-band Channel Assignment
0.6	22.11.2021	Value list updated
0.8	13.12.2021	Values and other updates
0.9	28.12.2021	Values and other updates
1.0	04.02.2022	Regulatory changes
1.1	17.5.2022	SL command and SW information updates